



The ModBox-OBand-28Gb/s-NRZ-SE provides production and R&D engineers a solution for Stress Receiver Sensitivity test & measurements in the O-Band.

This optical transmitter delivers the possibility to add variable stress to the high-quality NRZ clean eye diagram.

This O-band optical transmitter operates with data-rates from 155 Mb/s up to 28 Gb/s, and provides an independent solution for tunable stress magnitudes in both horizontal (jitter) and vertical (interference) eye axis (Stressed Eye).

It is primarily aimed at photoreceivers stressed sensitivity testing according to the 100 GbE IEEE 802.3ba standard. This unit is also used to test communication links and may be integrated to various telecommunication tests set-ups.

The ModBox-OBand-28Gb/s-NRZ-SE is a turn-key instrument delivering state of the art performance. It is being used in optical telecommunications laboratories and industrial production test beds.

This equipment embeds a modulation stage based on a chirp-free LiNbO₃ Mach-Zehnder modulator, coupled with a high performance RF driver and an automatic bias control circuitry. It also integrates a 1310 nm DFB laser source, and optional C-WDM lasers lanes.

In addition to the O-band, ixblue offers transmitters in the C-band and at 850 nm.

FEATURES

- Full O-Band Reference Transmitter
- NRZ Clean & Stressed Eye up to 28 Gb/s
- 100 GbE IEEE 802.3ba std compliant
- 1310 nm laser embedded (ITU-T G694.1)
- Reliable & reproducible measurements
- High eye diagram stability

APPLICATIONS

- 100 GbE testing
- Manufacturing and R&D receiver testing
- Fibre channel dispersion penalty testing
- Industrial production test
- R&D laboratories

OPTIONS

- C-WDM: 1270 nm, 1290 nm, 1330 nm
- Multi-Channel
- 850 nm, C-band ModBox versions

Performance Highlights

Parameter	Min	Typ	Max
Operating wavelength	1270 nm	1310 nm	1330 nm
Modulation format	NRZ Reference & Stressed eye modes		
Modulation bandwidth	Up to 28 Gb/s		
Modulated output power (option HP)	6 dBm	-	-

Functional Block Diagram

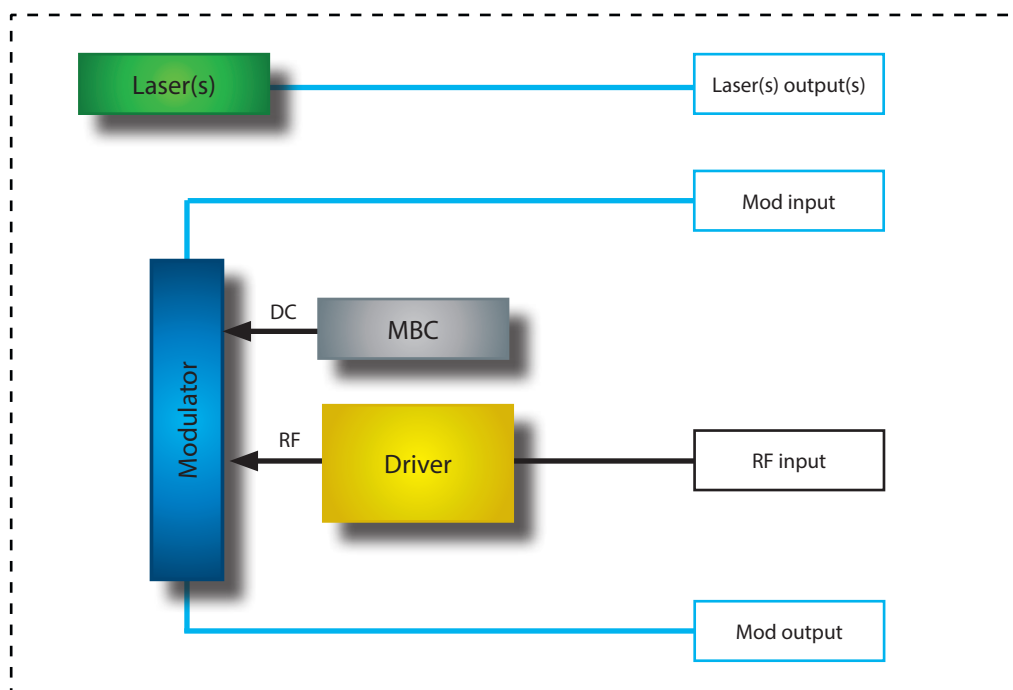

The ModBox-OBand-28Gb/s-NRZ-SE features:

- A chirp-free X-cut LiNbO₃ (Lithium Niobate) Mach-Zehnder Intensity modulator. It is selected for its high electro-optic bandwidth with flat and low ripple electro-optic response curve.
- A high bandwidth RF driver.
- A modulator bias controller. The internal LiNbO₃ modulator is a X-cut device with very low drift. However an automatic bias control circuit is provided to lock the operating point of the modulator at the quadrature point whatever the environmental and optical (laser power and wavelength) conditions. The MBC ensures a highly stable optical output signal to provide reliable and reproducible measurements.
- A 1310 nm low RIN laser is integrated by default. For convenience, an external patch cord is delivered to connect the laser output to the optical input of the modulation stage. Wavelength and power are tunable through the front panel controls or the ModBox software interface.

The ModBox-OBand-28Gb/s-NRZ-SE is controlled from the front panel via the Smart interface with a simple rotary knob and keypad. The Smart manual interface allows for bias control circuit, RF driver and laser settings. It comes also with a simple GUI solution, Windows based and implemented through the USB interface of the user PC.

From the RF input port, the user may add stress components to the base signal in order to produce stressed optical signals at the ModBox output. For example in the case of joint use with an Anritsu PRBS (type MP1900A), the user may add sinusoidal jitter, gaussian noise and a set of sinusoidal interference signals. The frequency and amplitude of each stress signals shall be chosen so that the optically stressed output signal complies with the 802.3ba standard for stressed receiver sensitivity testing.

Input Electrical Specifications User supplied, not a ModBox specification

Parameter	Symbol	Condition	Min	Typ	Max	Unit
Data-rate	-	NRZ electrical input signal	0.1	-	28	Gb/s
Input voltage	V_{IN}	AC coupled - 50 Ω Single Ended	0.100	0.250	0.400	Vpp
Rise / fall time	t_r / t_f	20 % - 80 % - NRZ @25.78125 Gb/s	13	15	18	ps
Corss-point	-	-	45	50	55	%

Input Optical Specifications User supplied, not a ModBox specification

Parameter	Symbol	Condition	Min	Typ	Max	Unit
Operation	λ	CW	1270	-	1330	nm
Polarization	-	-	Linear and controlled			-
Power	OP_{IN}	-	-	10	-	dBm
Side Mode Supression Ratio	SMSR	-	30	-	-	dB
Spectrum linewidth	$\Delta\lambda$	FWHM	-	1	-	MHz
Polarization Extinction ratio	PER	-	-	20	-	dB

SMART Interface and GUI

Parameter	Symbol	Condition	Min	Typ	Max	Unit
Wavelength laser tuning range	$\delta\lambda$	Diode chip temperature control	-	0.8	1	nm
Optical output power adjustment	δOP_{OUT}	Diode injection current control	0	-	100	%
Eye amplitude adjustment	-	-	-	3	-	dB
Eye crosspoint adjustment	-	-	-5	-	5	%

Absolute Maximum Ratings

Stresses in excess of the absolute maximum ratings can cause permanent damage to the device. These are absolute stress ratings only. Functional operation of the device is not implied at these or any other conditions in excess of those given in the operational sections of the data sheet. Exposure to absolute maximum ratings for extended periods can adversely affect device reliability.

Parameter	Symbol	Min	Max	Unit
Input voltage	V_{IN}	-	1	Vpp
Optical input power	OP_{in}	-	20	dBm

Output Optical Specifications

Specifications below are given with embedded 1310 nm laser, unless differently specified.

Parameter	Symbol	Condition	Min	Typ	Max	Unit
-----------	--------	-----------	-----	-----	-----	------

NRZ Reference mode (Unstressed eye diagram)

Jitter	J_{RMS}	RMS Jitter	-	0.8	-	ps
	J_{PP}	Peak-to-Peak Jitter	-	5	-	ps
Minimum dynamic extinction ratio	DER_{MIN}	By NRZ data input level adjustment	2	-	-	dB
Maximum dynamic extinction ratio	DER_{MAX}	By NRZ data input level adjustment	-	10	13	dB
Dynamic Signal to Noise Ratio	SNR	-	-	12	-	dB
Rise / fall time	t_r / t_f	-	8	-	10	ps
Crosspoint	-	-	45	50	55	%

NRZ Stressed eye mode ⁽¹⁾

Duty cycle distortion	DCD	-	0	-	0.1	%
Vertical eye closure penalty	VECP	@ 25.78125 Gb/s	-	1.9	-	dB
Jitter	J_2	@ 25.78125 Gb/s	-	0.33	-	ps
	J_4	@ 25.78125 Gb/s	-	0.48	-	ps
Dynamic extinction ratio	DER	By NRZ data input level adjustment	-	10	-	dB
Dynamic Signal to Noise Ratio	SNR	-	-	10	-	dB
Rise / fall time	t_r / t_f	NRZ mode	8	-	10	ps
Crosspoint	-	NRZ mode	45	50	55	%

General Specifications

Data format	-	-	NRZ Reference & Stressed eye modes			-
Data-rate	-	NRZ electrical input signal	0.1	-	28	Gb/s
Output modulated power	OP_{OUT}	With embedded 1310 nm laser	2	3	-	dBm
		High output power option @1310 nm	6	7	-	dBm
		Option: 1270 nm, 1290 nm, 1330 nm	2	3	-	dBm
Optical return loss	ORL	-	-40	-45	-	dB
Electrical Return loss	ERL	RF modulation in	-	-10	-	dB

Embedded laser Specifications

Embedded Laser	λ	DFB integrated by default	-	1310	-	nm
		CWDM DFB integrated in option	1270, 1290, 1330			nm
Side mode suppression ratio	SMSR	-	30	-	-	dB
Relative intensity noise	RIN	-	-	-150	-	dB/Hz

(1): A certain type of electrical noise (time and amplitude) is added from the PRBS to achieve stressed output optical signal.

Measurements & Related equipments

In this setup, the MP1900A from Anritsu generates electrically stressed signals displayed on a Keysight oscilloscope with a 50 GHz sampling module. The ModBox-OBand-28Gbps-NRZ-SE generates the optically referenced and stressed eyes. The scope is triggered by the MP1900A using a non jittered clock to allow for the optical signal jitter investigation. The scope embeds a jitter analysis software that allows us to spread the jitter data into individual constituents. We may then derive essential jitter metrics for the evaluation of the stress applied to the optical signal. In the following graphs you may notice the effect of adding a certain type of stress to the output optical signal.

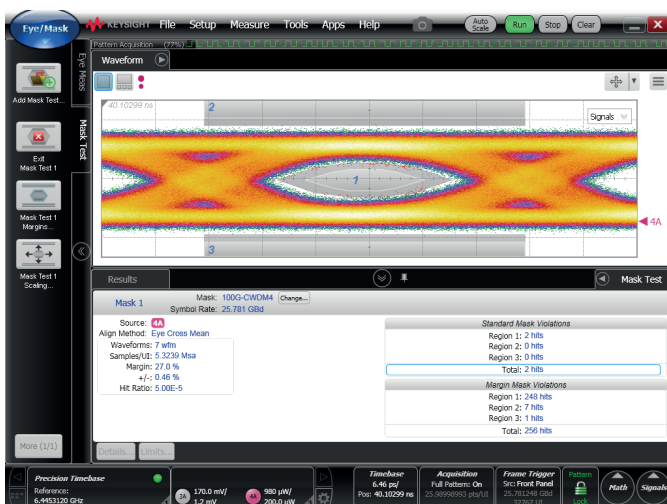
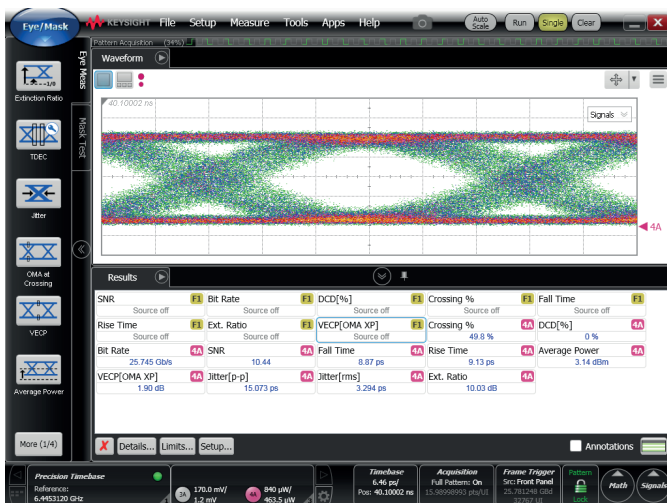
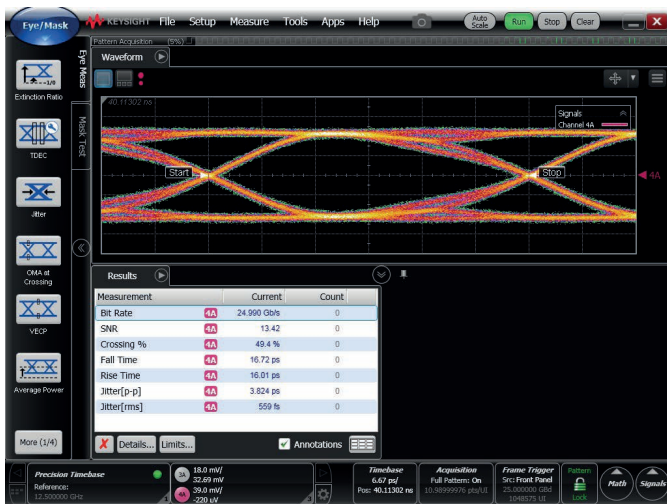

Interfaces, Dimensions and Compliance

Interfaces	
Optical	Polarization maintaining fiber PM1300 - FC/APC (by default, other connectors type in option)
RF input	Single 1.85 mm - V female RF connector - 50 Ω
Control	Smart Interface (front panel), GUI (USB typeB)
Power supply	100-120V/220-240 automatic switch 50-60Hz (Rear panel)
EMC / Optical norms	EN61326-1 Ed. 2006 / NF EN 60825-1 & EN 60825-2 Ed.2014
Dimensions / Weight	Rack 19" x 3U, Depth=375mm / 3 kg



LAN-WDM Laser ModBox example - Front panel

Ordering information

ModBox-OBand-28Gbps-NRZ-SE

OBand = Full band of operation, embeds laser, 1310 nm laser embedded by default
 28Gbps = Data-rate: NRZ up to 28 Gb/s

Opt-DFB-XX

DFB laser option

XX = Optional additional laser - CWDM Wavelength in nm

Opt-YY

YY = Output connectors, FA : FC/APC - FC : FC/UPC - SA : SC/APC- SC : SC/UPC

About us

ixBlue Photonics produces specialty optical fibers and Bragg gratings based fiber optics components and optical modulation solutions based on the company lithium niobate (LiNbO₃) modulators and RF electronic modules.

ixBlue Photonics serves a wide range of industries: sensing and instruments, defense, telecommunications, space and fiber lasers as well as research laboratories all over the world.